

operationsmanual

DGP-2 & DGP-2-V2 TUNGSTEN GRINDER
OPERATIONS MANUAL AND REPLACEMENT PARTS LIST



from **ARC-ZONE**[®]
.COM



Copyright©2017, Arc-Zone.com[®], Inc. All Rights Reserved

Arc-Zone.com, Inc.
2091 Las Palmas Drive, Ste. F
Carlsbad, CA 92011 - Tel. 1.760.931.1500
Email: info@arc-zone.com

TABLE OF CONTENTS

General

General Description	3
General Safety Information	3
Vacuum System Overview	3
Specifications	4
Unpacking	4
Warranty Information	4
Operator Information	5
Grinder Maintenance	6
Troubleshooting Chart	6
Mounting the DGP-2	7

Using the Equipment

Equipment Overview	7
Electrode Grinding [Assembly]	
The Basics	7
Operating	7
Tips for effective use	8
Recommended grinding times	8

Other Information

Exploded view of the DGP-2	9,11
Parts List	10,12
Accessories and Consumable Parts List	13



Copyright©2017, Arc-Zone.com®, Inc. All Rights Reserved

Arc-Zone.com, Inc.
2091 Las Palmas Drive, Ste. F
Carlsbad, CA 92011 - Tel. 1.760.931.1500
Email: info@arc-zone.com

Models DGP-2 and DGP-2-V2

1. GENERAL DESCRIPTION

The DGP-2 Tungsten Welding Electrode Grinder is designed specifically for the longitudinal grinding of the conical or tapered points on tungsten welding electrodes from .040" (1.0mm) to 3/16" (4.8mm) in diameter. This model also cuts these electrodes to precise lengths using a micrometer. This model also offers a multi-purpose grinding wheel for other shop uses. The grinder is equipped with a completely enclosed ball bearing motor and a rotor and shaft assembly that is dynamically balanced for vibration-free rotation. The motor housing is compact and the unit has ample side clearance on the grinding and aluminum oxide wheels. Wheel guards are secured to the shaft by threaded nuts and safety eyeshields are also included.

The DGP-2 and DGP-2-V2 Tungsten Electrode Grinders offer precise grinding for your precision welding needs. The DGP-2 consists of a horizontal axis grinder that can be pedestal mounted, a diamond grinding wheel and assembly on the right side, and a general purpose aluminum oxide wheel for general shop uses on the left side. The DGP-2-V2 adds foam-insulated cabinet, vacuum system for dust collection, and a flexible spotlight in addition to the DGP-2 features. The DGP-2 can be upgraded later to a DGP-2-V2.

The diamond grinding wheel on both grinders is on the right side of the machine and the surface rotates toward the electrode which provides consistent and repeatable points from each grind. The grinding surface faces right and the right wheel enclosure housing supports the electrode grinding assembly in addition to a Point Flat Dresser Block. The location of the area of contact between the diamond grinding wheel and the tungsten electrode is visible to the operator at all times, which allows for excellent control of the grinding operation. After repeated use, a groove will eventually be worn into the wheel at the contact point. The contact point should then be adjusted downward slightly to the next unused spot on the diamond grinding wheel. The grinding assembly on the left side also provides excellent visibility and is easy to operate for general grinding use, but is not recommended for tungsten because of the inferior finish it produces. Wheel rotation, viewed from the left end of the grinder, is clockwise. Both wheels have clear Plexiglas safety eyeshields.

VACUUM SYSTEM OVERVIEW

The DGP-2-V2 comes with a tool cabinet and integrated vacuum system for the collection of tungsten dust. This feature has become very popular due to notifications in the past few years about the danger of inhaling dust from the commonly used 2% Thoriated tungsten, is a known radioactive cancer-causing element. Please contact your local OSHA office if you would like more information about this issue. In addition, we offer free samples of non-radioactive alternative tungsten, which performs better in most applications. Users of the DGP-2 can later upgrade their systems to add the vacuum system if later chosen.

It is impossible to contain all of the lightweight dust particles that deflect quickly off the wheels from grinding. The vacuum system offers a way collecting the majority of the dust that is produced while grinding tungsten electrodes. Each side of the grinder has vacuum holes and hoses to collect dust. To maximize the suction power, use the valves at the back of the grinder motor to direct the suction to the side you are using. If you are using both sides at the same time, leave both sides open. However, if you are only using one side, close the valve on the opposite side you will increase the suction power to the side you are using.

Replacement vacuum filters are in stock at the factory for immediate shipment. Installation instructions come with replacement filters and is a simple process.



Copyright©2017, Arc-Zone.com®, Inc. All Rights Reserved

Arc-Zone.com, Inc.
2091 Las Palmas Drive, Ste. F
Carlsbad, CA 92011 - Tel. 1.760.931.1500
Email: info@arc-zone.com

2. SPECIFICATIONS

- Motor:** 1/3HP, 3450 RPM, 5.0 amps, 115/230 VAC, 50/60 Hz or 220 VAC, 50 Hz with step-down transformer option
- Wheels:** **Right side:**
Nickel Plated Diamond Wheel, 100% concentration, 6” diameter, .1535 face, 1.00” bore
- Left side:**
Diamond Cutting Wheel, 6” diameter
- Weight:** DGP-2: 27.2lbs./12.3kg
DGP-2-V2: 102lbs./46.4kg

3. UNPACKING

Checking for shipping damage. Arc-Zone.com takes great pride in providing quality equipment. If for some reason you find anything to be defective, please call us at: (760) 931-1500 and we will work with you to solve the problem. The following accessories are shipped with the DGP-2 and DGP-2-V2 grinders:

1. Pin Vise used to hold tungsten while grinding.
2. Six different Hex Keys, used to make various adjustments, and one Hex Screwdriver, used to secure the tungsten in the cutting apparatus.
3. Collets (two of your choice) – used to guide the tungsten and hold it at the proper angle while grinding.
4. Scale Setting Rod and Block - used to calibrate the angle positioner from time to time as the wheel becomes worn.

4. WARRANTY

The DGP-2 & DGP-2-V2 comes with a one-year warranty on parts and labor, excluding wheels that are a consumable part that naturally wears over time. This warranty also excludes abuse to the machine, dropping of the unit or improper handling by the operator.

5. SAFETY

Before any work is done, read the caution below carefully. Working safely prevents accidents.

- When not in use, turn the grinder off for safety purposes and to decrease wear on the machine.
- Wear proper apparel. Do not wear loose clothing, including gloves, neckties, rings, bracelets, or other jewelry, which may get caught, in moving parts of the machine.
- Wear protective hair covering to contain long hair.
- Wear safety glasses and a facemask.
- Never operate power tools when tired, intoxicated, or when taking medication that may cause drowsiness.
- Work area should have sufficient lighting.
- A proper electrical outlet should be available for the tools. A three-prong plug should be plugged directly into a three-prong outlet. Extension cord should be the correct gauge.
- Keep visitors at a safe distance from work area.
- Always unplug grinder prior to inspection.
- Read this manual thoroughly for specific adjustments and operating procedures.
- Do not perform “make-shift” repairs. Any part that is damaged should be promptly replaced.
- Only use the grinder for its intended purpose. Do not use it for a job it was not designed for.



Copyright©2017, Arc-Zone.com®, Inc. All Rights Reserved

Arc-Zone.com, Inc.
2091 Las Palmas Drive, Ste. F
Carlsbad, CA 92011 - Tel. 1.760.931.1500
Email: info@arc-zone.com

Safety (continued)

- Make sure that the grinder is off before plugging it in.
- Do not apply extreme force on the tungsten while grinding. This may cause your grinder to jam or cause premature grinding wheel wear.
- Never leave the grinder unattended. Turn the grinder off first and do not leave it until it comes to a complete stop.
- Keep hands away from moving parts.
- Know your grinder; learn its operation, applications, and specific limitations.
- Always unplug grinder prior to inspection.
- Read this manual thoroughly for specific adjustments and operating procedures.

6. OPERATOR INFORMATION

- Only use the grinder for its intended purpose. Do not use it for a job it was not designed for. Grinding parts other than tungsten will severely decrease wheel and equipment life.
- Unplug the grinder when changing accessories, such as collets, wheel, or other replacement parts.
- Avoid accidental start-up. Make sure that the grinder is in the off position before plugging it in.
- Do not force the grinder. It will work most efficiently at the rate for which it was designed. Consult the “Recommended Minimum Cutting and Grinding Time for New Electrodes” sticker on the grinder to determine optimum rate of speed.
- Use recommended accessories. Use of improper accessories may cause risk of injury of persons or accelerated wear on the grinder.
- Handle the tungsten and grinder correctly. Consult grinder operation procedures in this manual and handle tungsten with pin vise whenever possible to protect hands from possible injury.
- Feed tungsten into grinding wheel against the direction of rotation of the wheel.
- Turn the wheel off if it jams. A wheel jams when it digs too deeply into the tungsten (the motor force keeps it stuck in the tungsten).
- Never leave the grinder unattended. Turn the grinder off first and do not leave until it comes to a complete stop.
- Never stand or lean on the grinder. Serious injury could occur if the grinder is tipped or if the cutting tool is unintentionally contacted.
- Keep hands away from moving parts and cutting surfaces.

Operator Should Be Prepared For The Job:

- **Wear proper apparel.** Do not wear loose clothing gloves, neckties, bracelets, or other jewelry which may get caught in moving parts of the machine.
- **Wear protective hair covering** to contain long hair.
- **Wear safety shoes** with non-slip soles.
- Wear safety glasses. Prescription glasses have only impact resistant lenses.
- Wear face mask or dust mask.
- Be alert and think clearly. Never operate power tools when tired, intoxicated, or when taking medications that cause drowsiness.



Copyright©2017, Arc-Zone.com®, Inc. All Rights Reserved

Arc-Zone.com, Inc.
2091 Las Palmas Drive, Ste. F
Carlsbad, CA 92011 - Tel. 1.760.931.1500
Email: info@arc-zone.com

7. GRINDER MAINTENANCE

- Always unplug grinder before inspection.
- Keep the grinder clean for safest operation
- Remove adjusting keys and wrenches. Form a habit of checking that keys and adjusting wrenches are removed before the grinder is turned on.
- Keep all safety guards in place and in good working order.
- Keep all parts in working order. Check to determine that the guard or other parts will operate properly and perform their intended functions.
- Check for damaged parts and alignment of moving parts, binding of moving parts, breakage of mounting parts and any other condition that may affect the grinders operation. Consult DGP factory for replacement parts at: (805) 498-3837.

Work Area Should Be Ready For The Job

- Keep work area clean.
- Do not use power tools in dangerous environments, such as damp or wet locations. Do not expose power tools to rain.
- Work area should be properly lighted.
- The proper electrical outlet should be available for the tool. For 110V, a three prong plug should be plugged directly into a three prong outlet and /or extension cord.
- Keep visitors a safe distance from work area and keep children out of work place. Use padlocks, master switches, and remove starter keys to prevent any unintentional use of power tools.

8. TROUBLESHOOTING CHART

SYMPTOMS	POSSIBLE CAUSES(S)	CORRECTIVE ACTION
Grinder won't start	1. Blown line or tripped circuit breaker	1. If fuse is blown, replace with fuse of proper size. If breaker is tripped, reset it.
	2. Low line voltage	2. If voltage is less than rated, check size of wiring from main switch on property. If OK, contact power company.
	3. Material wedged between wheel and guard	3. Remove material wedged between wheel and guard
Excessive vibration	1. Improper mounting of grinder or accessories	1. Remount
	2. Improper wheel mounting	2. Remount wheels but rotate one wheel 1/4 turn with respect to its previous position. Other wheel would retain its original position.
Grooved wheel	1. Electrode pushed with excessive force	1. Use recommended grinding times table
	2. On steep angled tungsten, collet touching wheel	2. Use short collets available from Diamond Ground Products
Motor is overheating	1. Motor not turning freely (without power)	1. Clean around wheels & shaft. Then replace bearings



Copyright©2017, Arc-Zone.com®, Inc. All Rights Reserved

Arc-Zone.com, Inc.
 2091 Las Palmas Drive, Ste. F
 Carlsbad, CA 92011 - Tel. 1.760.931.1500
 Email: info@arc-zone.com

9. MOUNTING THE DGP-2

The DGP-2 stand alone grinder (without vacuum system and cabinet) should be mounted to a solid horizontal surface (mounting hardware is not provided).

If mounted to a metal cabinet or pedestal, align the mounting holes with the corresponding holes in the cabinet or pedestal. Insert a ¼”-20-1 ¼” hex head bolt with flat washer beneath the head of the grinder. From the bottom of the cabinet or pedestal, place a ¼” flat washer and ¼”-20 hex nut onto the bolt extension. Tighten only until the space between the grinder base and the cabinet or pedestal is 1/8”. Using a second nut on each bolt, jam tightens against the first to prevent loosening by vibration.

If mounted to a wooden bench top, use ¼” wood screws that are 1 ¼” long with flat washer beneath the heads. Tighten screws until the space between the grinder base and the bench is 1/8”.

10. ELECTRODE GRINDING ASSEMBLY

The Basics

The Electrode Grinding Assembly is attached to the right wheel housing (refer to Figure 1 for the general arrangement of the assembly). It provides the means to support an electrode in a fixed position relative to the diamond-grinding surface through an electrode guide collet that matches the electrode diameter. The electrode is brought into gentle contact with the diamond-grinding surface and at the same time is rotated slowly in one direction between the operator’s thumb and forefinger. As an alternative, pin vises are also provided to hold the tungsten during rotation. Note: all positioning and adjustment should be made before turning on the grinder.

Operation Instructions

Please refer to Figure 1 on the next page for the optimum location of the electrode point contact area with respect to the grinding surface. In the position shown, the motion of the diamond grinding wheel surface is parallel to the centerline of the electrode to accomplish longitudinal grinding of the electrode point. When grinding very steep angles, such as 10°, be careful that the electrode guide collet does not make contact with the diamond grinding wheel. This can contaminate the wheel and reduce the life of the wheel significantly. For these types of angles, you may need to consult the factory to obtain optional short collets that available for these applications.

Refer to Figure 2 on the next page for use with the following operation instructions:

1. If the tungsten you are using is already flat at the end, like new tungsten straight out of the box, proceed to Step 4.
2. Locate the Point Flat Dresser Block (DGP-F180) attached at the 12 o’clock position of the right side wheel cover. Find the hole that matches the diameter of your tungsten and turn on the grinder.
3. Select the electrode guide collet with the hole diameter closest to the tungsten electrode diameter and position it in the electrode guide collet tube. Notice that the collet has been beveled on a 15° angle at the front or exit end of the collet. With this surface parallel to the grinding wheel surface, tighten the set screw to hold it in place. The back, or entrance, end of this collet has been milled down to its center line to make it



Copyright©2017, Arc-Zone.com®, Inc. All Rights Reserved

Arc-Zone.com, Inc.
2091 Las Palmas Drive, Ste. F
Carlsbad, CA 92011 - Tel. 1.760.931.1500
Email: info@arc-zone.com

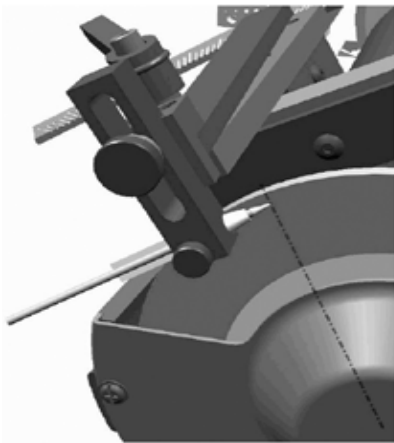

Figure 1: Optimal location of electrode point contact area

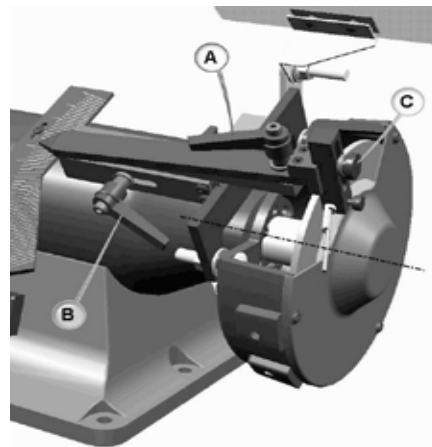

Figure 2: Electrode grinding assembly

Electrode Grinding Assembly Cont'd

5. Left to right positioning: Adjust the position of the electrode grinder assembly using the horizontal adjustment knob (Handle B) to place beveled surface of the electrode guide collet approximately 1/64" from the grinding surface.
6. Slip a tungsten electrode into and through the electrode guide collet to determine where it will contact the grinding disk surface.
7. Up and down positioning. Adjust the electrode grinder assembly using the vertical adjustment knob (Knob C) so that the tungsten electrode will contact the actual grinding surface.
8. Remove the tungsten electrode from the electrode guide collet.
9. Put the eyeshield in place and start the grinder. Slide the tungsten electrode into and through the electrode guide collet and twirl the electrode (or the pin vise holding the electrode) slowly in one direction between thumb and forefinger as it approaches and makes contact with the grinding surface. To retain maximum symmetry of the point, try to keep from moving the electrode side to side within the collet. The best technique for this is to constantly lean the electrode against the inside surface of the collet while turning. Continue grinding until the desired sharpness is obtained. Make sure to continue rotation as the electrode is backed off from the wheel or a spot may occur along the point. Contamination of the wheels can occur by using the diamond grinding and cutting wheels as all-purpose shop wheels. If you grind tools or other metal items, other than electrodes, there is always the risk of contaminating the wheels.

In addition to proper positioning and avoiding contamination, use the recommended grinding times in Table 1 below to increase the longevity of the diamond grinding wheels. The wheel can be used with very limited wear by working according to these guidelines. Wear of the wheel will double if the grinding time is reduced by one half using more applied force and wear will triple if the time is reduced by one third. Be patient and do not gouge the wheel!

For users requiring extreme tolerances, a laser cut tip/flat gauge is available from Diamond Ground Products to accurately measure tip diameter. See page 13 for the part number. Also note, a microscope or comparator can be used to verify the angle (taper) of the grind in a very precise and efficient manner.

Electrode Diameter (In.)	Electrode Diameter (mm)	Grinding Time
.040"	1.0mm	5-8 sec
1/16"	1.6mm	11-15 sec
3/32"	2.4mm	15-20 sec
1/8"	3.2mm	25-35 sec
5/32"	4.0mm	30-40 sec
3/16"	4.8mm	55-65 sec

Table 1: Recommended grinding times for each diameter.

Consult Appendix A from Illustrated Parts brochure and optional Accessories



Copyright©2017, Arc-Zone.com®, Inc. All Rights Reserved

Arc-Zone.com, Inc.
 2091 Las Palmas Drive, Ste. F
 Carlsbad, CA 92011 - Tel. 1.760.931.1500
 Email: info@arc-zone.com

11. EXPLODED VIEW (LEFT SIDE)

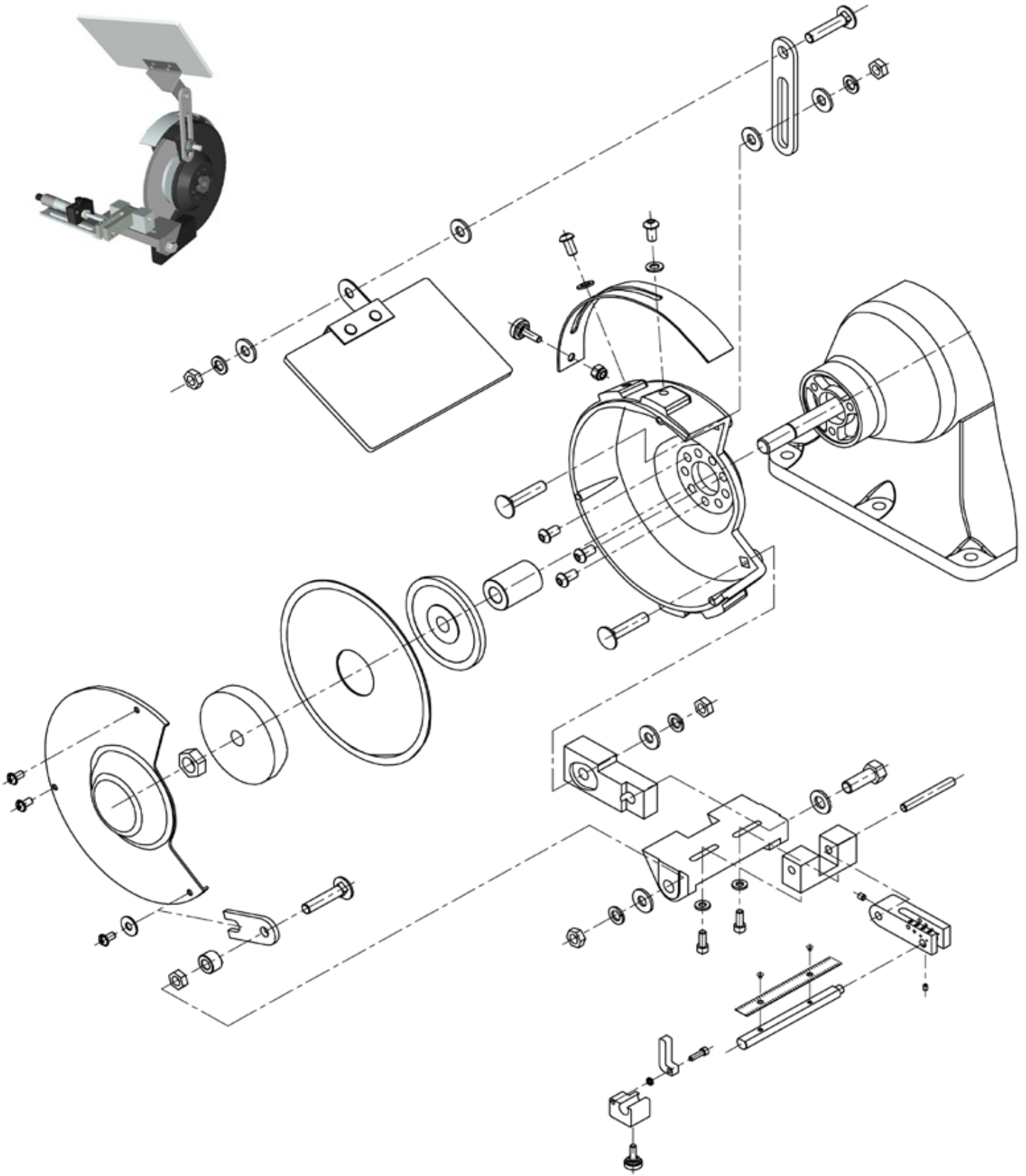

Copyright©2017, Arc-Zone.com®, Inc. All Rights Reserved

Arc-Zone.com, Inc.
2091 Las Palmas Drive, Ste. F
Carlsbad, CA 92011 - Tel. 1.760.931.1500
Email: info@arc-zone.com

12. PARTS LIST (LEFT SIDE)

ITEM	PART NUMBER	DESCRIPTION	QTY
1	DGP-F010-A	ARBOR SPACER	1
2	DGP-P307	BASE - ELECTRODE - LEFT SIDE - MOD FOR DGP-2 & -3	1
3	DGP-P310	BOLT - HEX HD - 3/8"-16 X 1 SST	2
4	W/GRINDER	CARRIAGE BOLT 5/16-18 X 1-1/2	3
5	DGP-P662-A	EYESHIELD BRACKET SET	4
6		EYESHIELD PLEXIGLAS	1
7	DGP-F120	SECONDARY SAFETY STRIP	1
8	DGP-F167-A	HUB - INNER FOR DGP-2 AND 3 LEFT SIDE	1
9	DGP-F175-A	HUB - OUTER FOR DGP-2 AND 3 LEFT SIDE	1
10	DGP-P460	KNOB - #10 SHEAR-LOC - 5/8 OD - BLACK	1
11	W/GRINDER	LEFT WHEEL INSIDE COVER	1
12	W/GRINDER	LEFT WHEEL OUTSIDE COVER	1
13	DGP-F232	NUT - HEX - 5/16-18	2
14	DGP-P494	NUT - HEX - LOCKING NYLON INSERT - #10-32 STL	2
15	DGP-F233	NUT - HEX 1/2-12 LH THREAD	1
16	DGP-PG1396	SCREW - BHC - 1/4-20 X 1/2 - ALLOY - BLACK	2
17	W/GRINDER	SCREW - FLANGED - 1/4-20 X 1/2	3
18	W/GRINDER	SCREW - PAN HEAD - #10-24 X 3/8	3
19	DGP-PG1397	SCREW - SHC - #10-32 X 5/8 SST	1
20	W/GRINDER	SPACER - 5/16 ID X 19/32 OD X 3/8	1
21	DGP-F050	SUPPORT ARM - LEFT SIDE	1
22	W/GRINDER	UPRIGHT BAR	1
23	W/GRINDER	UPRIGHT BAR (CUT IN HALF)	1
24	DGP-P700	WASHER - FLAT - 1/4 ID X 1/2 OD X .05 SST	2
25	DGP-P705	WASHER - FLAT - 1/4 X 5/8 SST	1
26	DGP-P725	WASHER - FLAT - 3/8	1
27	W/GRINDER	WASHER - FLAT 5/16	4
28	W/GRINDER	WASHER - LOCK 5/16	3
29	W/GRINDER	MOTOR SHAFT - LEFT SIDE	1
30	W/GRINDER	MOTOR HOUSING - LEFT SIDE	1
31	DGP-P735	WHEEL - CUT-OFF	1
32	DGP-F040	BLOCK - DGP-2 CUT-OFF INDEXER	1
-	DGP-F130	CUT-OFF FORK ASSY FOR DGP-2	1
33	-	BAR - RULER SUPPORT	1
34	-	CUT-OFF FORK	1
35	DGP-F190	PIVOT BLOCK FOR DGP-2 & -3	1
36	DGP-F205	PIVOT SHAFT FOR DGP-2 & -3	1
37	-	SCREW - SET - #4-40 X 3/16 SST	1
38	DGP-F150	HANDLE - DGP-2 CUT OFF INDEXER	1
39	DGP-P450	KNURLED KNOB - #8 SHCS - 1/2 OD - BLACK	1
40	DGP-P520	SCALE - DGP-2 - INCH - SST FLEX (STANDARD)	1
	DGP-P530	SCALE - DGP-2 - METRIC - SST FLEX (OPTIONAL)	1
41	DGP-P610	SCREW - FHS - #2-56 X 1/8 - SST	2
42	DGP-PG1387	SCREW - SHC - #10-32 X 1/2 - ALLOY - BLACK	2
43	DGP-P570	SCREW - SHC - #6-32 X 1/2 - ALLOY - BLACK	1
44	DGP-P570	SCREW - SHC - #8-32 X 1/2 - ALLOY - BLACK	1
45	DGP-P550	SCREW - SET - #8-32 X 3/16 - CUP POINT - ALLOY - BLACK	1
46	DGP-P723	WASHER - FLAT - #10 X 7/16 OD X .05 THK SST	2
47	DGP-PG1398	WASHER - SPLIT LOCK - #6 SST	1
48	DGP-PG1399	SCREW - SHC - 3/8-16 X 3/4 - ALLOY - BLACK	1



Copyright©2017, Arc-Zone.com®, Inc. All Rights Reserved

Arc-Zone.com, Inc.
 2091 Las Palmas Drive, Ste. F
 Carlsbad, CA 92011 - Tel. 1.760.931.1500
 Email: info@arc-zone.com

13. EXPLODED VIEW (RIGHT SIDE)

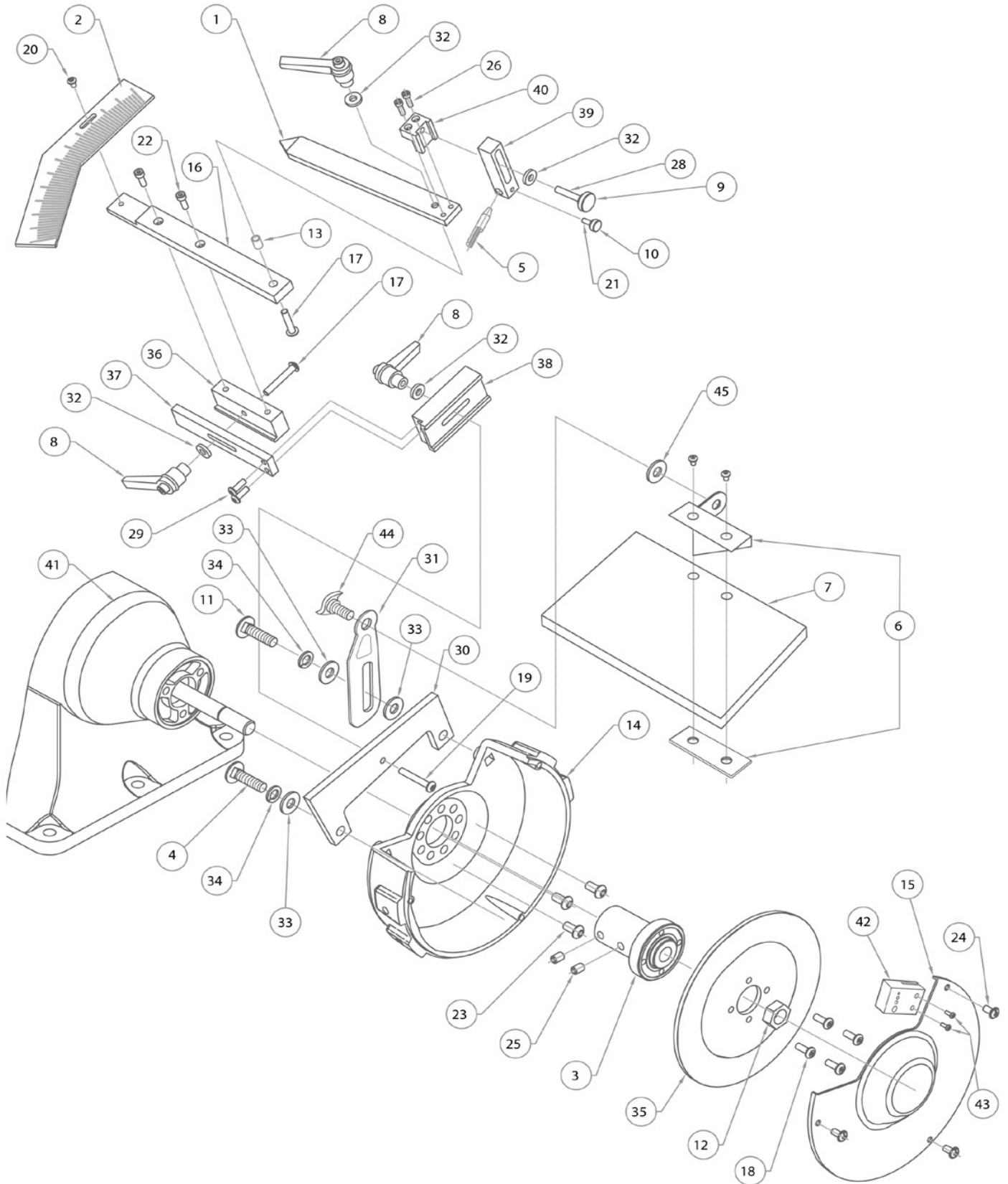

Copyright©2017, Arc-Zone.com®, Inc. All Rights Reserved

Arc-Zone.com, Inc.
 2091 Las Palmas Drive, Ste. F
 Carlsbad, CA 92011 - Tel. 1.760.931.1500
 Email: info@arc-zone.com

14. PARTS LIST (RIGHT SIDE)

ITEM	PART NUMBER	DESCRIPTION	QTY
1	DGP-F007	ANGLE POINTER	1
2	DGP-F025	ANGLE SCALE	1
3	DGP-F142	WHEEL ARBOR	1
4	DGP-P177	BOLT - HEX - 3/8" - 16 x 3/4" HEXBOLT HEAD	1
5	DGP-F060	COLLET - .040" (1.0mm)	CHOICE OF 4
	DGP-F070	COLLET - 1/16" (1.6mm)	
	DGP-F080	COLLET - 3/32" (2.4mm)	
	DGP-F090	COLLET - 1/8" (3.2mm)	
	DGP-F100	COLLET - 5/32" (4.0mm)	
	DGP-F110	COLLET - 3/16" (4.8mm)	
6	DGP-P662-A	EYESHIELD BRACKET SET R/S	1
7	DGP-P663-A	EYESHIELD PLEXIGLASS R/S	1
8	DGP-P410	HANDLE - ADJUSTABLE CLAMPING	3
9	DGP-P460	KNOB - #10 SHEAR-LOC - BLACK	1
10	DGP-P440	KNOB - #6 SHEAR-LOC - BLACK	1
11	DGP-P310	BOLT - HEX - 3/8" 16 X 1	1
12	DGP-F231	NUT - HEX 1/2"-12 RH THREAD	1
13	DGP-F200	PIVOT BUSHING (GRINDING) 10-32	1
14	DGP-F277	RIGHT WHEEL INSIDE COVER	1
15	DGP-F278	RIGHT WHEEL OUTSIDE COVER	1
16	DGP-F225	SCALE SUPPORT BAR	1
17	DGP-P661	SCREW - BHC - #10-32 X 1" - ALLOY - BLACK	2
18	DGP-P1442	SCREW - BHC - #10-32 X 1/2" - ALLOY - BLACK	4
19	DGP-P660	SCREW - BHC - #10-32 X 1-1/4" - ALLOY - BLACK	1
20	DGP-P541	SCREW - BHC - #6-32 X 1/4" - ALLOY - BLACK	1
21	DGP-P1320	SCREW - BHC - #6-32 X 3/8" - ALLOY - BLACK	1
22	DGP-P570	SCREW - BHC - #8-32 X 1/2" - ALLOY - BLACK	2
23	DGP-PG536	SCREW - FLANGED - 1/4"-20 X 1/2"	3
24	DGP-P178	SCREW - PAN HEAD - #10-24 X 3/8"	3
25	DGP-PG1439	SCREW - SET - 1/4"-20 X 3/8" - ALLOY - BLACK	2
26	DGP-PG1320	SCREW - SHC - #6-32 X 3/8" - ALLOY - BLACK	2
28	DGP-PG1363	SCREW - SHC - #10-32 X 1" - ALLOY - BLACK	1
29	DGP-P542	SCREW BHSCH BLK #8-32 X 1/2"	2
30	DGP-F230	SUPPORT BRACKET	1
31	DGP-F222	UPRIGHT BAR	1
32	DGP-P730	WASHER - FLAT - #10 X 1/2" OD X 3/32"	4
33	DGP-P725	WASHER - FLAT 3/8"	3
34	DGP-P724	WASHER - SPLIT LOCK 3/8"	2
35	DGP-PG1426	WHEEL - DIAMOND - 300 GRIT (STANDARD)	1
	DGP-PG1425	WHEEL - DIAMOND - 600 GRIT (OPTIONAL)	1
36	DGP-F242	X-AXIS CLAMP BLOCK	1
37	DGP-F245	X-AXIS GUIDE BAR	1
38	DGP-F255	Y-AXIS CLAMP BLOCK	1
39	DGP-F260	Z-AXIS CLAMP BLOCK	1
40	DGP-F270	Z-AXIS GUIDE BRACKET	1
41	DGP-P400	GRINDER - BENCH 6" SINGLE PHASE 1/3 HP	1
42	DGP-F180-A	BLOCK POINT FLAT DRESSER	1
43	DGP-P550	SCREW SET SHC CUP	1
44	DGP-P179	1/4"-20 X 3/8" KNOB	1
45	DGP-PG1334	1/4" WASHER FLAT SS	1



Copyright©2017, Arc-Zone.com®, Inc. All Rights Reserved

Arc-Zone.com, Inc.
 2091 Las Palmas Drive, Ste. F
 Carlsbad, CA 92011 - Tel. 1.760.931.1500
 Email: info@arc-zone.com

15. ACCESSORIES AND CONSUMABLE PARTS LIST

Description		Part no.
300 Grit Grinding Wheel - For grinding .040" to 3/32" (1.0mm to 2.4mm)		DGP-PG1425
600 Grit Grinding Wheel - For grinding 3/32" to 3/16" (2.4mm to 4.8mm)		DGP-PG1426
Diamond Cutting Wheel		DGP-P735
Vacuum Filters (Cartridge type for vacuum units only)		DGP-M968
Upgrade to Vacuum System (Includes cabinet, vacuum system and flexible spotlight)		DGP-UPG
Carrying Case (For transporting stand-alone unit to site work.)		DGP-P345
Flexible Spotlight (with bulb)		DGP-P480
Replacement Bulb for Flexible Spotlight (110V / 220V version)		DGP-P490
Tip/Flat Gauge (For measuring the diameter of the tip/flat)		DGP-F145
Replacement Collets:	.040" (1.0mm)	DGP-F060
	1/16" (1.6mm)	DGP-F070
	3/32" (2.4mm)	DGP-F080
	1/8" (3.2mm)	DGP-F090
	5/32" (4.0mm)	DGP-F100
	3/16" (4.8mm)	DGP-F110
Cabinet Only (no vacuum or flexible spotlight)		DGP-P330
Replacement Grinder Switch		DGP-P667
Pin Vises:	Small .040"-1/16" (1.0mm to 1.6mm)	DGP-P513
	Medium 1/16" to 1/8" (1.6mm to 3.2mm)	DGP-P514
	Large 1/8" to 3/16" (3.2mm to 4.8mm)	DGP-P515



Copyright©2017, Arc-Zone.com®, Inc. All Rights Reserved

Arc-Zone.com, Inc.
 2091 Las Palmas Drive, Ste. F
 Carlsbad, CA 92011 - Tel. 1.760.931.1500
 Email: info@arc-zone.com